

Attack on INS Hanit An Analysis of the Event

By Christopher Carlson



Key Judgments

- ◆ While patrolling off Beirut during the 2006 Hezbollah war, INS *Hanit*, a Sa'ar 5 light frigate, was hit by an anti-ship cruise missile
- ◆ The lack of significant hull or superstructure damage fueled a long debate as to the type of missile that hit the Israeli warship
 - C802/Noor and C701 were the two missile candidates
- ◆ The missile was a C802/Noor that detonated after hitting the bulky loading crane based on photography of the damage and the recollection of a crew member
 - Internet references to the missile detonating after hitting the safety railing can't be supported based on fuze time delay and location of damage
 - Crane theory first articulated in The Naval SITREP: The Journal of the Admiralty Trilogy Game System, Issue #31, October 2006
- ◆ The C802/Noor approached directly from astern, likely hit the safety railing, which pitched the missile downward and struck the crane low to the deck
 - Highly localized damage indicates the missile exploded just above the deck (<1.0 meter)
- ◆ *Hanit* was very fortunate, a direct hit would have crippled the small frigate



Israeli – Hezbollah Conflict of 2006

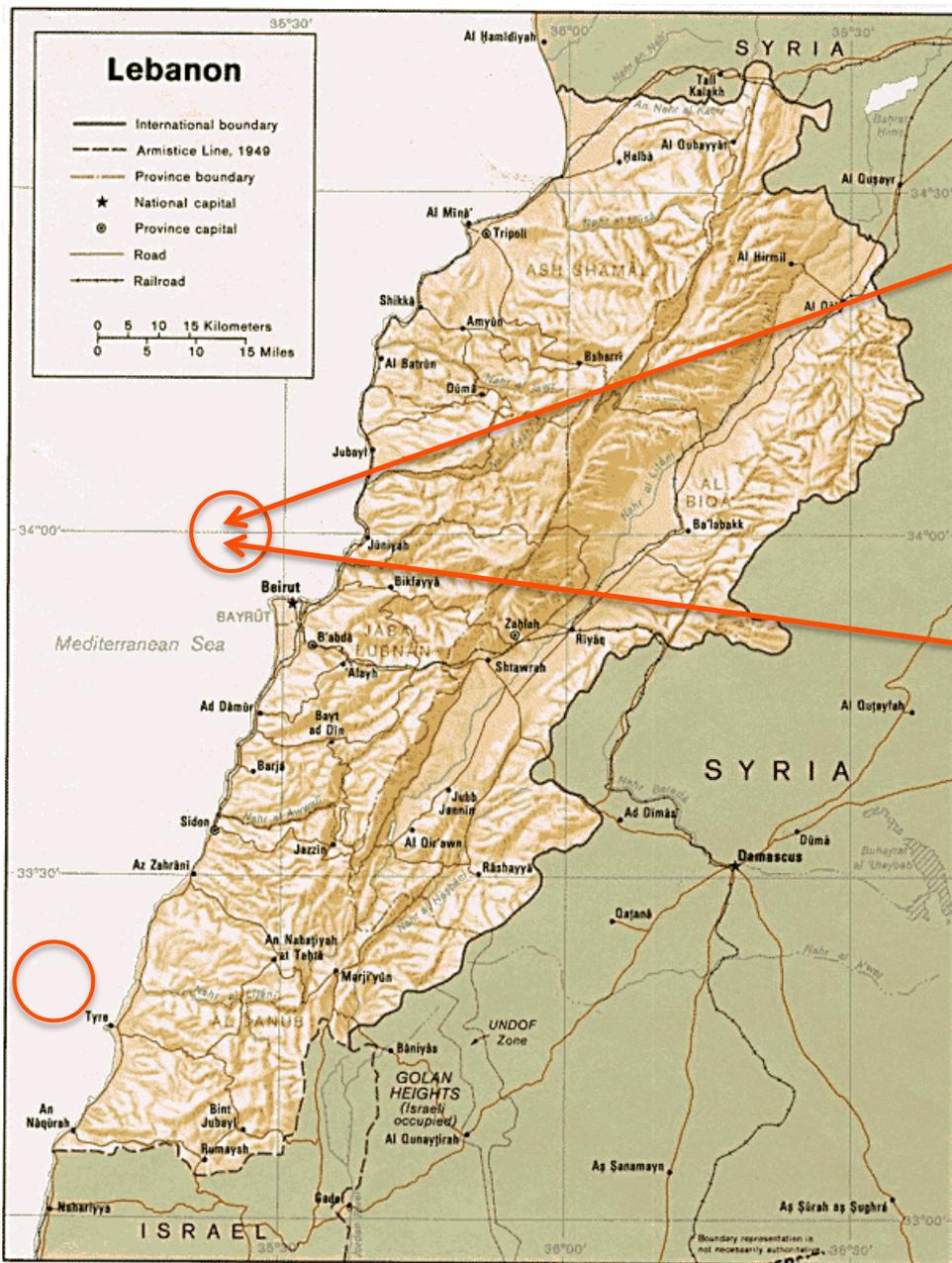

Sa'ar 4.5 PTG



INS Hanit, Sa'ar 5 FFL

- ◆ The Israeli Navy conducted blockade operations off Tyre and Beirut during the 2006 Hezbollah war. INS *Hanit* was providing air defense and command & control support for at least one Sa'ar 4.5 PTG as it shelled targets in Beirut with its 76mm cannon.

Missile Engagement

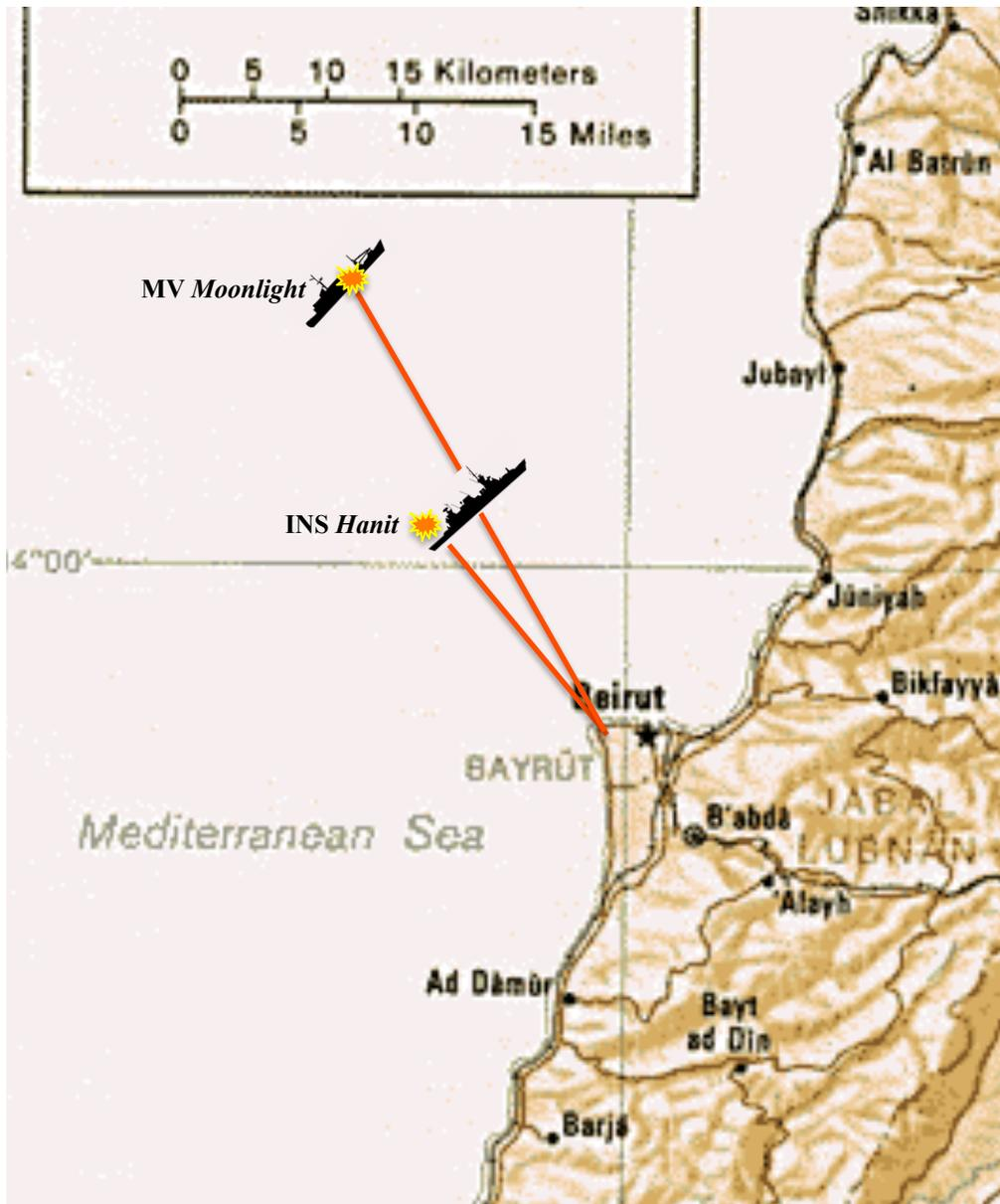

- ◆ On 14 July 2006, two or three anti-ship cruise missiles (ASCM) were fired by Hezbollah and IRGC personnel at INS *Hanit*. According to Israeli sources, coastal surveillance radars provided firing data to the mobile missile battery.
- ◆ One missile hit INS *Hanit* in the stern, causing a fire and killing four of the crew. The second missile missed the Israeli frigate, but locked on and hit a small Cambodian registered merchant ship, MV *Moonlight*, which sank. The reporting on the range of the merchant vessel from the coast varies between 35 to 70 kilometers.
- ◆ The attack took place well after sunset at approximately 2030 local time. INS *Hanit* was patrolling off Beirut, about 16 kilometers from the coast. The exact position of the Israeli combatant and Cambodian merchant have not been provided. Thus, the illustration to the left is a representational view of the attack.

INS *Hanit* Hit - Battle Damage Assessment



- ◆ **INS *Hanit* returned to the Ashod Naval Base under her own power**
 - **Damage was apparently relatively light given the C802/Noor's warhead size**
 - **Numerous websites and professional journals suggested a smaller missile, such as the C701, had hit the frigate near the waterline**
 - **Photos like the one above noted the black soot aft, suggesting the hit location**

INS *Hanit* Hit - Battle Damage Assessment



- ◆ ***Problem:*** The proposed hit location (circled in red) is actually one of four diesel exhausts associated with the propulsion/electrical plant
- ◆ The forward exhaust (circled in yellow) was not initially noticed, and there are two others on the port side as well
- ◆ Waterline level exhaust for diesel engines is a common infra-red signature reduction technique

INS *Hanit* Hit - Battle Damage Assessment

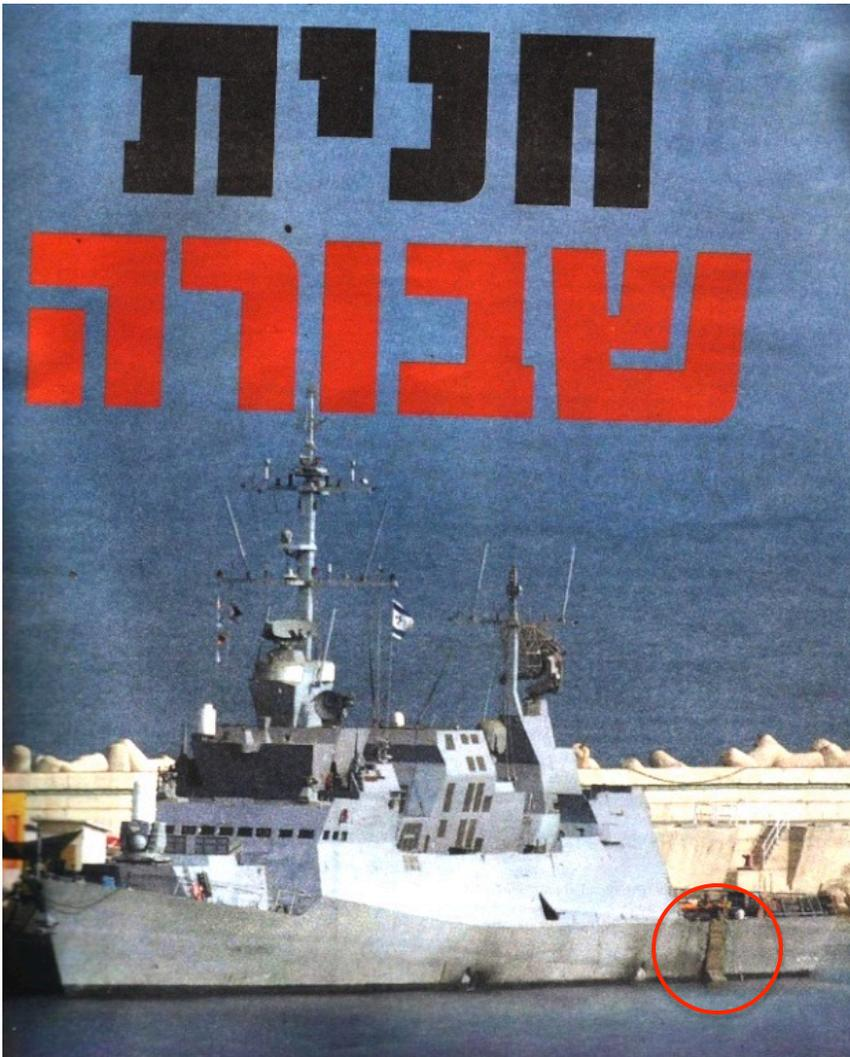

- ◆ A newspaper photo of INS *Hanit* showed very little observable damage
 - Just a mat or canvas covering over the port side, aft of the helicopter hangar
- ◆ This fueled online debates as to the reason for the light damage. The most popular theories included:
 - A smaller missile, such as the C701, hit *Hanit*
 - A larger missile, like the C802, had a proximity fuze and exploded before actually hitting the hull
 - A larger missile hit, but the warhead failed to detonate
- ◆ None of the above theories provide a satisfactory explanation
 - Even a direct hit by a failed warhead would have cause far more damage than what was seen; as in the case of the much larger HMS *Sheffield*

INS *Hanit* Repaired – Three Weeks Later



- ◆ **INS *Hanit* was noted underway again on 6 August 2006, a little over three weeks after the attack**
- ◆ **There was no evidence of any significant structural damage**
 - **Repairs from a direct ASCM hit could not have been completed so quickly**
 - **Note the areas of fresh paint and the missing crane**

Typical ASCM Damage



- ◆ Photo is from the SinkEx of the former *USS Buchanan*, DDG-14
- ◆ Small hole is from a Harpoon missile with a telemetry module
- ◆ Large hole is from two warshot Harpoon missiles with real warheads
 - Harpoon warhead: 221.6 kg
 - C802 warhead: 165 kg
 - C701R warhead: 29 kg
 - If INS *Hanit* had been hit by any missile – *it would be obvious*

Possible Candidate Missiles – C802/NOOR



- ◆ **Chinese C802 ASCM**
 - Noor is an Iranian copy
- ◆ **Max Range: 120 km**
- ◆ **Speed: Mach 0.80-0.90**
- ◆ **Warhead: 165 kg**



Possible Candidate Missiles – C701T



- ◆ Chinese display of the TV-guided C701
 - Later designation: C701T
 - Electro-optical TV only
 - No infra-red capability
- ◆ Max Range: 15 km
- ◆ Speed: Mach 0.80
- ◆ Warhead: 29 kg



Possible Candidate Missiles – C701R



Photo : Hossein Fatemi

FARS NEWS AGENCY

- ◆ Chinese display of the radar-guided C701
 - Later designation: C701R
 - Longer than C701T
- ◆ Max Range: 25 km
- ◆ Speed: Mach 0.80
- ◆ Warhead: 29 kg

What Missile Hit INS *Hanit*?

- ◆ **C701T despite being discussed at length in news articles is not a viable candidate**
 - *Hanit's* distance from the coast exceeded the C701T's max range
 - Attack occurred at night, EO TV guidance would not see the target
- ◆ **C701R was not mentioned even though Internet photos showed it in the IRGC inventory earlier in 2006**
 - Missile has sufficient range and uses radar guidance
- ◆ **At least one C802/Noor missile was known to have been fired**
 - MV *Moonlight* could only have been engaged by a C802/Noor given that the range at impact was between 35 and 70 kilometers
- ◆ **The proposed “Hi-Low” attack theory in numerous defense journals and articles with two types of missiles doesn't make a lot of sense**
 - Theory suggested a C701 shot low, C802/Noor shot high
 - Combining both missile systems on a single launch vehicle is not a realistic option – fire control and sensor requirements for C701 demands two vehicles
 - But it is more difficult to get two transporter-erector-launchers (TEL) into the country, and it's more difficult to coordinate the attack between multiple TELs
 - Also, C802/Noor missile's cruise altitude is set at 20 or 30 meters, typical sea skimmer heights, and cannot execute a “high flight profile” after boost phase

What Missile Hit INS *Hanit*?

- ◆ Most likely candidate is a C802/Noor ASCM
- ◆ **Argument for a C802/Noor**
 - At least one C802/Noor was launched on the evening of 14 July 2006
 - A single TEL with three missiles can account for the attacks on both ships
 - Some reports state a third missile was launched, but exploded early in flight – consistent with a C802/Noor mobile launcher
 - Hits by two C802/Noor ASCMs would very likely sink a Sa'ar 5 FFL
- ◆ **Argument against a C802/Noor**
 - Damage is inconsistent with the large 165 kg warhead
- ◆ ***But the observed damage is inconsistent with any of the possible missiles***



Inconsistencies with INS *Hanit* Damage

- ◆ **Damage to *Hanit* was slight, and she was back to sea in a few weeks**
 - Even the 29 kg bulk high explosive warhead of a C701R would have done more damage than was observed if it had hit the ship directly
- ◆ **A failed fuze on a C802/Noor missile is an unlikely option**
 - Reported and observed damage was confined to an area immediately aft of the hangar, this is inconsistent with a direct hit on the ship itself by a malfunctioning missile
- ◆ **The observed damage *is* consistent with an explosion away from the hull or superstructure**
 - However, no ASCM would deliberately use a proximity fuze as the primary fuze
 - ASCM warheads are semi-armor piercing with a time delay contact fuze

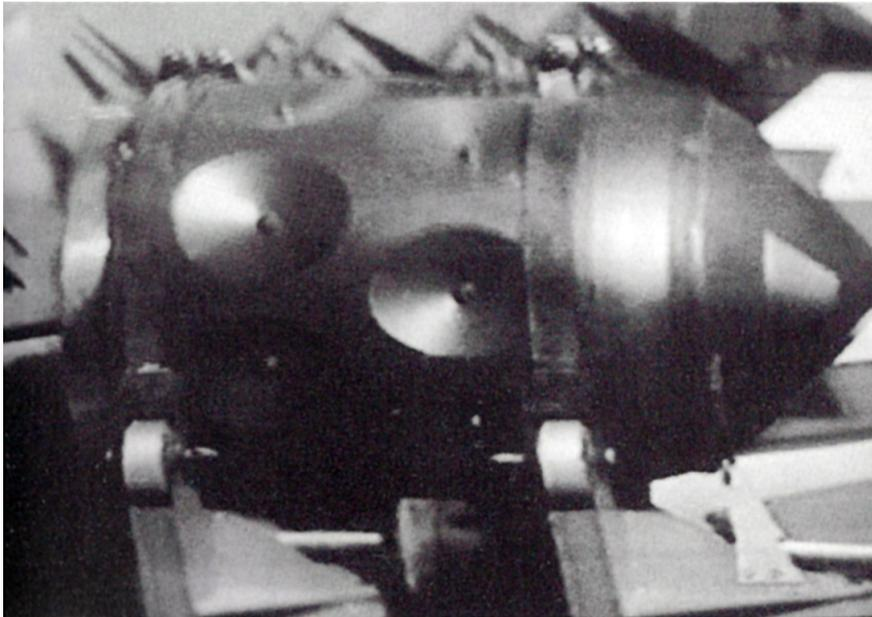

The YJ-8 series of anti-ship cruise missiles (C801/C802) use a semi-armor piercing, blast/fragmentation warhead design that employs multiple shallow explosively formed projectiles. The primary damage envelope radiates outward, perpendicular to the warhead's longitudinal axis. The explosively formed penetrators or EFPs are designed to extend the affected damage radius inside the target. The blast and fragmentation damage effects along the longitudinal axis are considerably less. This type of warhead requires the target be penetrated to maximize the damage effects. A proximity fuze is completely inconsistent with this type of warhead design.

Hypothesis: What if the missile hit the crane?

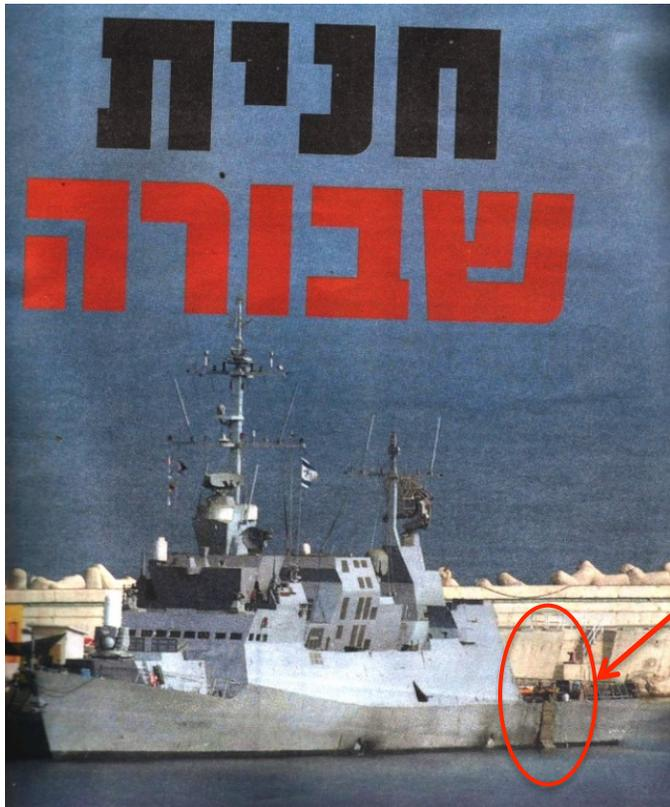

- ◆ **The covered area of the hull is just outboard of where the crane is mounted**
 - Note there is no sign of the crane, although it is possible it was removed
- ◆ **Hitting the crane provides a viable alternative theory**
 - It is a radar hotspot on an otherwise reduced RCS hull and superstructure
 - Crane base is at the right height, a C802/Noor missile's terminal altitude is 5 or 7 meters
 - It is massive enough to take the impact, initiate the fuze, and absorb most of the forward blast and fragments

Hypothesis: What if the missile hit the crane?



- ◆ The canvas covered hull section matches perfectly with the newly painted hull section on *Hanit* as she left harbor on 6 August 2006
- ◆ That section of the hull is adjacent to where the large crane was mounted
- ◆ Hypothesis was first published in The Naval SITREP: The Journal of the Admiralty Trilogy Game System, Issue #31, October 2006, pages 4-6

2007 Update



- ◆ The *Strategy Page* website, on 7 February 2007, posted a Tel Aviv news report that discussed the attack on INS *Hanit*
 - Claim is made that the missile struck one of the foldable safety rails surrounding the helicopter deck
 - The peripheral safety net is about 4.9 meters above the water when raised

“The missile that struck the *Hanit* actually exploded after hitting a railing at the rear of the ship and did not penetrate the aft deck. According to naval officials here, the impact destroyed the aft electrical switchboard and caused extensive fire damage, but the fully redundant, highly shock resistant, compartmentalized Sa’ar-5 used its forward electrical power source to return to port.”

2007 Update

- ◆ On the *Information Dissemination* website, the 5 and 6 July 2007 entries discussed the attack on INS *Hanit* in two parts
 - In Part I, the poster relates an article by an Israeli Rabbi based on a discussion with a *Hanit* crew member
 - Crew member explicitly states the missile hit the crane
 - Caveat: He saw only the aftermath, not the actual impact
 - The safety railing and crane are approximately 16.9 meters apart – too far for both to be involved with detonating the warhead

Lazer Beams

Tuesday , 17 October 2006

The Miracles of Hanit

“Then, all of us had a Shabbat meal together - 15 different sailors said Kiddush, each in the custom of his fathers; I'm talking about guys that aren't (weren't) even religious! The meal was drawn out - I had a headache and was dying to sleep. The religious guys started to say the grace after the meal, and BOOOFF! **The missile hit, but on the opposite end of the craft. It should have sank the boat, but it hit a crane right above the chopper landing pad.** What a miracle! If that's not enough, the helicopter-refueling tank - filled to the gills with chopper fuel - didn't explode despite the fact that the whole end of the boat was burned...”

http://lazerbrody.typepad.com/lazer_beams/2006/10/the_miracles_of.html

2007-08 Update

- ◆ In late 2007 and early 2008, photographs of INS *Hanit* at the Ashod Naval Base began showing up on websites illustrating the extent of the damage



Safety Railing Theory - Unsupportable

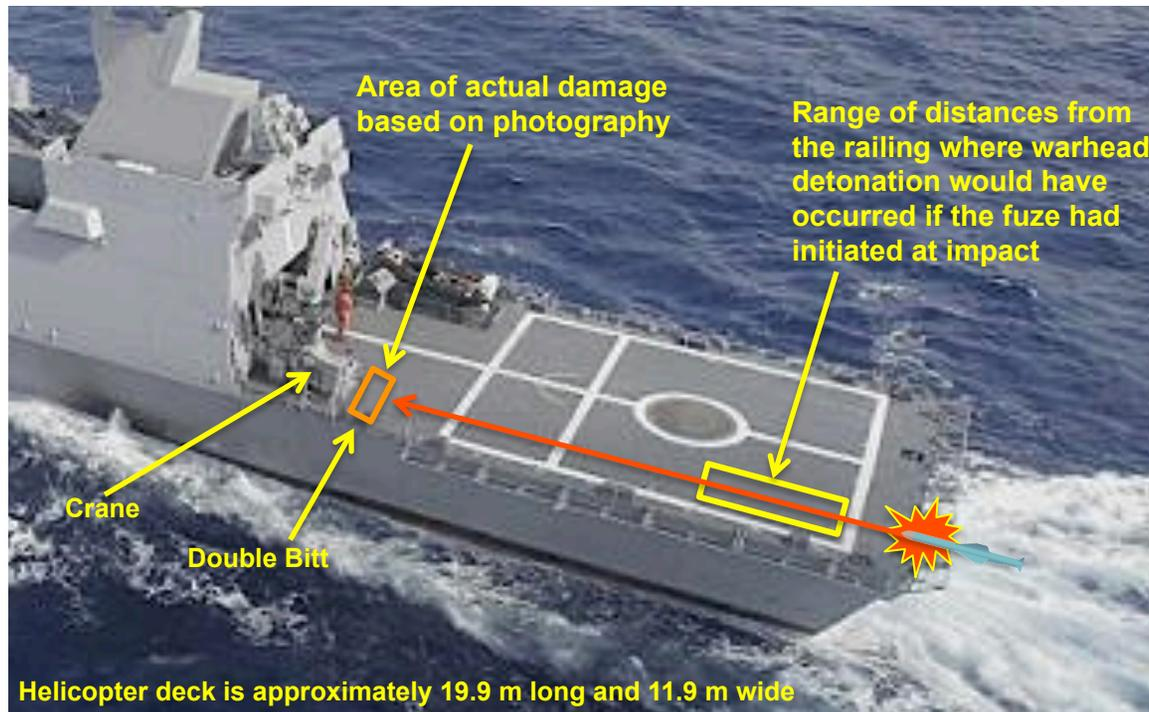

- ◆ **If the missile struck the safety railing head on, and the fuze was initiated, the warhead would have detonated quite far away from the crane**
 - Yellow box shows the distances for all combinations of C802 missile speed (Mach 0.8 – 0.9) and fuze delays for blast/fragmentation ASCM warheads (8 – 15 milliseconds)
 - Orange box indicates the area of damage, approximately 2.5 times further away
- ◆ **It is possible that the missile's body, more likely one of the wings, hit the railing, but the contact was not sufficient to initiate the fuze**
 - When raised, the peripheral safety net railing is about 4.9 meters above the water, a C802 at the 5 meter terminal altitude would be at the correct height to strike the railing

Crane Theory Confirmed



- ◆ **The missile struck the crane aft of the ship's superstructure**
 - Double bitt confirms the hit location of the C802/Noor ASCM
- ◆ **Damage is consistent with a 165 kg multiple EFP warhead**
 - Much of the warhead's damage effects was wasted on open air
- ◆ **Given the orientation of the gash in the helicopter deck, the missile's trajectory appears to have been from directly astern of the ship**
 - Phalanx CIWS, even if it were in automatic mode, would not have been able to engage - masked by ship's superstructure
 - Barak SAM would have had a fleeting chance to engage – but would require automatic mode, this was not selected

Engagement Analysis

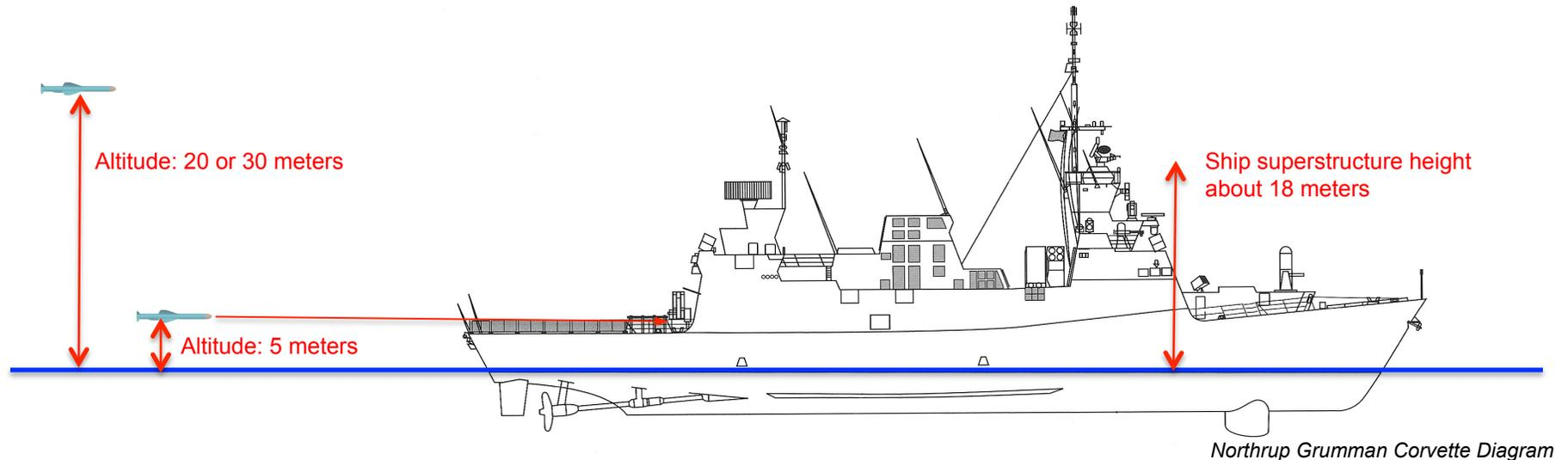

- ◆ **Hezbollah and IRGC personnel fired two, possibly three, C802/Noor ASCMs at INS *Hanit* at a range of about 16 kilometers**
 - One missile reportedly explodes soon after launch (sparse evidence for this)
 - Boost phase lifts a C802/Noor to about 250 meters altitude
 - One missile apparently did not get down quick enough and flew over *Hanit* at or near the cruise altitude of 20 or 30 meters
 - Minimum stated engagement range of the C802 is 15 kilometers
 - This missile continued down range and struck the MV *Moonlight*
- ◆ **The other missile's radar seeker acquired the crane, began homing, and descended to a terminal altitude of 5 meters**

Note: Northrup Grumman Corvette diagram was used as a detailed, scaled drawing of a Sa'ar 5 frigate was not found

Engagement Analysis

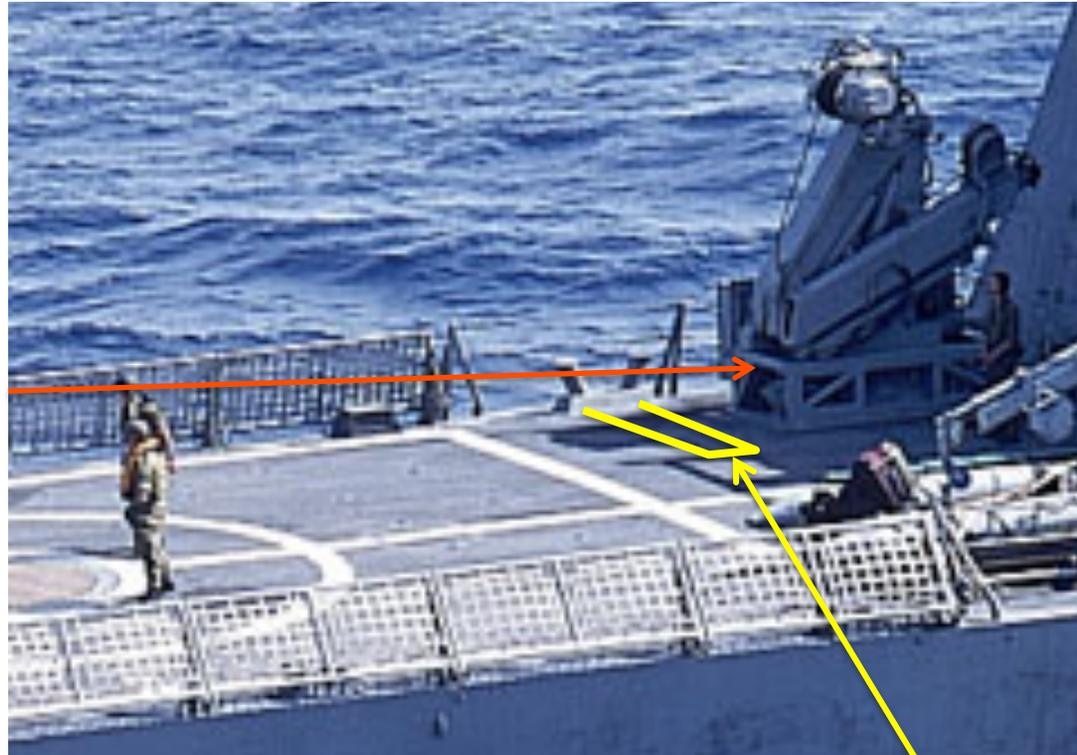

- ◆ **As the C802/Noor flew over *Hanit's* stern, the missile body, or more likely one of the wings struck the safety net railing**
 - **The sudden impact by a wing would create a moment that would rotate the missile's nose downward**
 - **Observed fire damage is forward of the gash in the deck and biased to port, suggesting that the port missile wing struck the railing**



C802 Warhead

Warhead Length: ≈ 0.70 meters
Explosive Section Length: ≈ 0.35 meters
Warhead Diameter: ≈ 0.32 meters
Total Warhead Weight: 165 kilograms

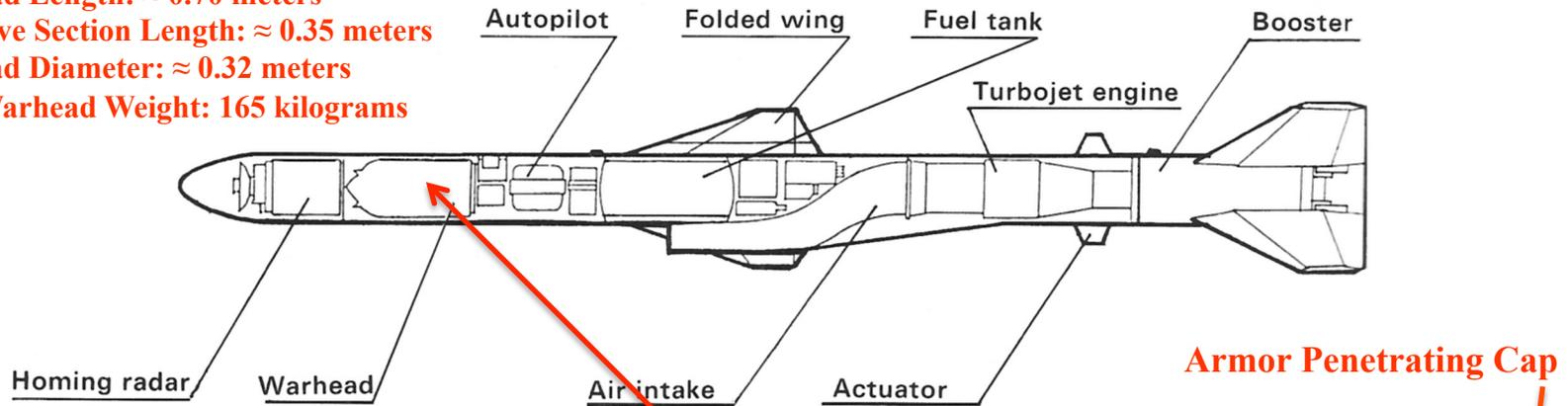

Armor Penetrating Cap
Explosively Formed Penetrator
Explosive Section

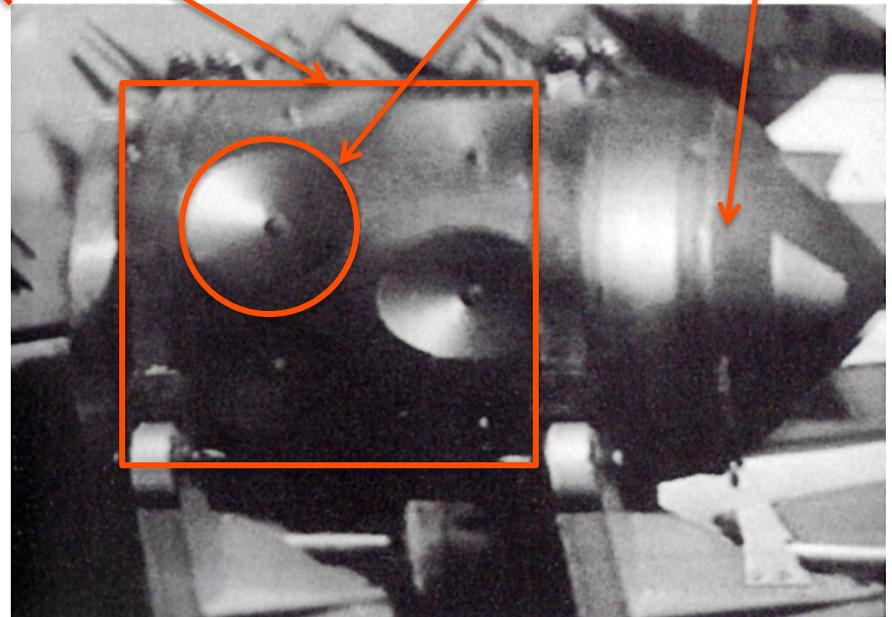

- ◆ Warhead uses 16 shallow shape charges to form large, high-speed projectiles, - explosively formed penetrators or EFPs
- ◆ Copy of the West German Kormoran-1 missile warhead – same design and weight
- ◆ Blast and fragmentation damage expands out radially along the warhead's longitudinal axis (perpendicular to the axis)
- ◆ Considerably less damage effects in the fore and aft direction (parallel to axis)

Damage Analysis



- ◆ **No significant structural damage to the helicopter hangar or aft superstructure**
 - Flimsy hangar door and aft countermeasure launcher were destroyed by the blast
 - No evidence of a direct hit by the missile on any part of the helicopter hangar, note the lack of any fragment exit holes through the side of the hangar
 - Soot on the port side of the helicopter hanger indicates the fire was confined to the deck on the port side near the impact area

Helicopter Deck Damage

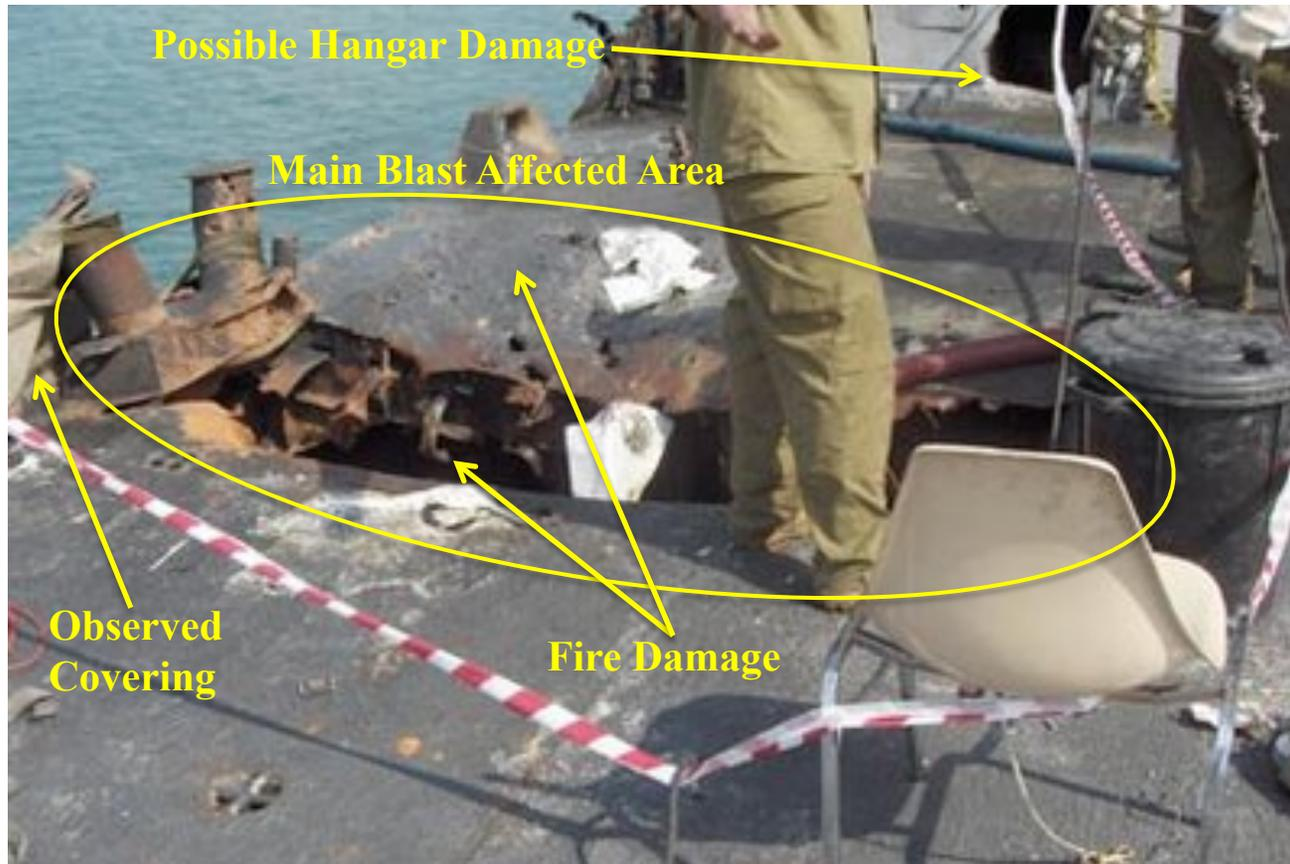

- ◆ **Crane was destroyed, remnants have been removed**
 - Hole in the lower port side of the hangar could have been caused by either a large missile fragment, or more likely crane debris
 - Fire damage topside is forward of the gash and biased to port
- ◆ **Highly localized structural damage to the helicopter deck just aft of the crane's former position is consistent with a multiple EFP warhead**

Helicopter Deck Damage



- ◆ **Narrow blast damage swath, strongly suggests warhead detonation occurred close to the deck – less than 1.0 meter**
- ◆ **Evidence of large size fragments that penetrated down into the engineering spaces – very likely caused by an EFP**
- ◆ **Note the significant fire damage**

Helicopter Deck Damage



- ◆ Large gash in the helicopter deck is approximately 1.6 to 1.8 meters in length and 0.4 to 0.5 meters in width
- ◆ Damaged area is roughly rectangular in overall shape – consistent with the damage from a C802-type warhead detonating very close to the deck
- ◆ Forward momentum would propel the burning fuel in the direction of the missile's movement – angled slightly to port
 - Remnants of crane protected the helicopter hangar from being splashed with burning fuel
- ◆ Fuel would flow down the dished in portion of the helicopter deck and pour into the gash and other small holes, causing the reported fire below decks

Conclusions

- ◆ **Testimony by an eyewitness and photography of the ship during repairs confirms the hypothesis that a C802/Noor ASCM struck the large crane located on the aft port side of INS *Hanit***
- ◆ **Damage to INS *Hanit* is consistent with a 165 kg multi-EFP warhead fitted to a C802/Noor ASCM that exploded away from the ship's superstructure**
 - The warhead detonated less than one meter above the deck
 - Highly localized damage to the helicopter deck is key
- ◆ **The C802/Noor missile that hit INS *Hanit* functioned properly**
 - The engagement was very near the advertised minimum range of 15 kilometers
 - The missile that flew over apparently didn't get down to cruise altitude in time to allow the seeker to acquire the target
 - The Sa'ar 5's low RCS also reduced the probability of acquisition
 - Crane likely had a relatively large RCS in comparison to the rest of the ship
- ◆ **INS *Hanit* was a very fortunate ship, the crane was both a curse and a blessing**
 - A curse because the crane's larger RCS likely attracted the missile to INS *Hanit* in the first place
 - A blessing in that the crane absorbed the brunt of the missile's impact and shielded the ship's superstructure from the warhead's blast, fragments, as well as the burning fuel, thus considerably reducing the damage to the ship